



IPIX[®] InSight[™] Camera



IS-N2000

INSTALLATION INSTRUCTIONS

SAFETY PRECAUTIONS



CAUTION: TO REDUCE THE RISK OF ELECTRICAL SHOCK, DO NOT OPEN COVERS. NO USER SERVICEABLE PARTS INSIDE. REFER SERVICING TO QUALIFIED SERVICE PERSONNEL.

This label may appear on the bottom of the unit due to space limitations.



The lightning flash with an arrowhead symbol within an equilateral triangle is intended to alert the user to the presence of uninsulated "dangerous voltage" within the product's enclosure that may be of sufficient magnitude to constitute a risk of electric shock to persons.



The exclamation point within an equilateral triangle is intended to alert the user to presence of important operating and maintenance (servicing) instructions in the literature accompanying the appliance.

WARNING: TO PREVENT FIRE OR SHOCK HAZARD, DO NOT EXPOSE INTERNAL COMPONENTS TO RAIN OR MOISTURE.



Attention: Installation should be performed by qualified service personnel only in accordance with the National Electrical Code or applicable local codes.

For 24 VAC Installations:

Do Not Exceed 26.4 VAC Input. Voltage applied to the unit's power input should not exceed 26.4 VAC. Normal input voltage is 24 VAC. User supplied wiring from 24 VAC supply to unit must be in compliance with electrical codes (Class 2 power levels). Do not ground 24 VAC supply at power supply terminals or at unit's power supply terminals.

SECURITE



ATTENTION

**RISQUE D'ÉLECTROCUTION.
NE PAS OUVRIR**



DANGER: POUR ÉVITER TOUT RISQUE D'ÉLECTROCUTION, NE PAS OUVRIR LE BOÎTIER. IL N'Y A PAS DE PIÈCES REMPLAÇABLES À L'INTÉRIEUR. POUR TOUTE RÉVISION, S'ADRESSER À UN TECHNICIEN SPÉCIALISÉ.

En raison de limitation de place, cette étiquette peut être placée sur le dessous de l'appareil.



L'éclair fléché dans un triangle équilatéral, avertit l'utilisateur de la présence d'une "tension dangereuse" non isolée à l'intérieur de l'appareil et d'une valeur suffisante pour constituer un risque d'électrocution.



Le point d'exclamation contenu dans un triangle équilatéral, avertit l'utilisateur de la présence, dans la documentation qui accompagne l'appareil, de consignes d'utilisation et de maintenance importantes.

AVERTISSEMENT : RISQUE D'INCENDIE OU DE CHOCS ELECTRIQUES. NE PAS EXPOSER LES COMPOSANTS INTERNES A LA PLUIE NI A L'HUMIDITE.



Attention: L'installation doit être effectuée uniquement par du personnel de service qualifié conformément à la réglementation du Code Electrique National ou à la réglementation locale.

Pour Installations à 24 V c.a. :

Ne pas excéder 26.4 VCA. La tension appliquée à l'entrée d'alimentation de l'appareil ne devrait pas excéder 26.4 VCA. Toute installation électrique fournissant du 24 Volts courant alternatif doit être conforme ax codes électriques. (Niveaux d'alimentation de la Classe 2). Ne pas brancher une prise de terre sur les bornes d'alimentation 24 Volts ou ax bornes d'alimentation de l'appareil.

SICHERHEITSVORKEHRUNGEN



VORSICHT
STROMSCHLAGGEFAHR!
BITTE NICHT ÖFFNEN!



VORSICHT: UM EINEN ELEKTRISCHEN SCHLAG ZU VERMEIDEN, ABDECKUNG NICHT ENTFERNEN. WARTUNGEN ALLER ART QUALIFIZIERTEM PERSONAL ÜBERLASSEN.

Aus Platzgründen kann diese Warnung auf der Unterseite des Gerätes angebracht sein.



Das Blitzsymbol im gleichseitigen Dreieck soll den Benutzer auf nicht isolierte "Hochspannung" im Gehäuse aufmerksam machen, die eventuell stark genug ist, um einen elektrischen Schlag zu verursachen.



Das Ausrufezeichen im gleichseitigen Dreieck soll den Benutzer auf wichtige Bedienungs- und Wartungsanleitungen in der dem Gerät beigefügten Literatur aufmerksam machen.

WARNUNG: SCHÜTZEN SIE DIE INNEREN KOMPONENTEN VOR REGEN UND FEUCHTIGKEIT, UM BRÄNDE ODER ELEKTRISCHE SCHLÄGE ZU VERMEIDEN.



Achtung! Die Installation sollte nur von qualifiziertem Kundendienstpersonal gemäß jeweilig zutreffender Elektrovorschriften ausgeführt werden.

Für Installationen bei 24 V Wechselspannung:

Achtung! 26.4 Volt Eingangswchselspannung darf für 24 VAC Modelle nicht überschritten werden. Normal-betrieb findet bei 24 Volt Wechselspannung statt. Die Kabel- bzw. Drahtverbindung vom Netzgerät zu dem vor-liegenden Gerät muß die Bestimmungen der Schutz-klasse II erfüllen. Nicht die 24-Volt-Leitung erden weder am Netzgerät noch an den Anschlußklemmen des vorlie-genden Gerätes.

PRECAUCIONES DE SEGURIDAD



PRECAUCION

RIESGO DE CHOQUE
ELECTRICO. ¡NO ABRIR!



PRECAUCION: PARA REDUCIR EL RIESGO DE CHOQUE ELÉCTRICO, FAVOR NO ABRIR LA CUBIERTA. ESTE EQUIPO NO CONSTA DE PIEZAS O PARTES QUE REQUIEREN SERVICIO O MANTENIMIENTO. PARA REPARACIONES FAVOR REFERIRSE A UN TÉCNICO CALIFICADO.

Debido a limitaciones de espacio, esta etiqueta puede aparecer en la parte inferior de la unidad.



El símbolo representado por un relámpago con punta de flecha dentro de un triángulo equilátero, se muestra con el objetivo de alertar al usuario que existen "voltajes peligrosos" sin aislamiento, dentro de la cubierta de la unidad. Dichos voltajes pueden ser de tal magnitud que constituyen un riesgo de choque eléctrico a personas.



El símbolo de exclamación dentro de un triángulo equilátero, se muestra con el objetivo de alertar al usuario de que instrucciones de operación y mantenimiento importantes acompañan al equipo.

ADVERTENCIA: PARA EVITAR RIESGOS DE INCENDIOS O DESCARGAS ELÉCTRICAS, NO EXPONGA LOS COMPONENTES INTERNOS A LLUVIA NI A HUMEDAD.



Atención: La instalación de este equipo debe ser realizada por personal capacitado, solo en acuerdo, y en cumplimiento de normas del "National Electric Code" (Código Eléctrico Nacional) ó las normas del Gobierno Nacional Local.

Para instalaciones de 24 V (CA):

No exceder 26.4 VCA de entrada. Voltage suplido a la unidad no debe exceder 26.4 VCA. Voltage de entrada normal es de 24 VCA. El cableado de 24 VCA provisto por el usuario debe cumplir con las normas eléctricas (Clase 2 de niveles de alimentación). No conectar los 24 VCA a tierra en las terminales de la alimentación ó a las terminales de la fuente de alimentación de la unidad.

FCC & ICES INFORMATION

(U.S.A. and Canadian Models Only)

WARNING - This equipment has been tested and found to comply with the limits for a Class B digital device, pursuant to Part 15 of the FCC Rules and ICES-003 of Industry Canada. These limits are designed to provide reasonable protection against harmful interference when the equipment is operated in a commercial environment. This equipment generates, uses, and can radiate radio frequency energy and, if not installed and used in accordance with the instruction manual, may cause harmful interference to radio communications. Operation of this equipment in a residential area is likely to cause harmful interference in which case the user will be required to correct the interference at his own expense. Intentional or unintentional changes or modifications not expressly approved by the party responsible for compliance shall not be made. Any such changes or modifications could void the user's authority to operate the equipment.

If necessary, the user should consult the dealer or an experienced radio/television technician for corrective action. The user may find the following booklet prepared by the Federal Communications Commission helpful: "How to Identify and Resolve Radio-TV Interference Problems." This booklet is available from the U.S. Government Printing Office, Washington, DC 20402, Stock No.004-000-00345-4.

1. UNPACKING

Unpack carefully. This is an electromechanical device and should be handled with care. Check to ensure that the following items are included:

- Camera with lens
- Power supply (85-265 VAC, 50/60 Hz) and adapters
- IPIX Camera Manager (ICM) CD

2. SERVICE

If the unit needs repair service or parts, please contact IPIX customer service at 877-337-4749 for a return authorization as well as shipping instructions.

3. DESCRIPTION & SPECIFICATIONS

The IPIX® InSight™ Camera is a small, high performance, 2 mega-pixel network camera that provides ultra high quality video and immersive imaging. The camera can be used with any standard CS-mount lens and can be ordered with a 7.0-70mm 1/2" format manual varifocal lens.

Construction/Finish: Aluminum housing with powder coat finish.

4. INSTALLATION

Attention: Installations should be performed by qualified service personnel only in accordance with the National Electrical Code or applicable local codes.

4.1 Connecting Low Voltage Power & Network

Power and network wiring should be run in an appropriate manner to the location of the camera (see Figure 1).

4.1.1 Connecting With 24VAC Power Source

The voltage supplied to the unit must be in the range of 21.6 to 26.4 VAC. The unit is not polarity sensitive. Conductors should be sized accordingly for 4-watts of power consumption.

A power connector (terminal block) is supplied with the camera and accepts 18-28 ga wire. Wires should be stripped to 0.275" (7mm) and inserted into the terminal block as shown (see Figure 1, Detail A). The terminal block should be connected to the camera with the wired terminals 1 and 2 on the far side of the ethernet connection and secured in place by the 2 screws.

4.1.2 Connecting With 12VDC Power Supply

The camera comes with a 85-265 VAC input power adapter that is supplied with pre-stripped power leads for the low voltage side of the power adapter. These wires should be inserted into the power connector (terminal block) supplied with the camera. The terminal block should be connected to the camera and secured in place by the 2 screws (see Figure 1).

The line voltage side of the power adapter should be attached to the power source in a manner consistent with local electrical codes.

4.1.3 Connecting Network Cable

The camera uses a standard RJ45 Ethernet connection.

4.2 Focusing

The focus is preset at the factory. However, if the unit is out of focus, it can be adjusted using the following procedures:

1. With the camera connected, place the camera in position and aim it at the area to be viewed.
2. Loosen the zoom ring locking stem and the focusing stem by turning them counterclockwise (see Figure 1).
3. Turn the zoom ring to the desired field of view (fov).
4. Move the focusing stem to adjust the focus. With the unit in focus, turn the zoom ring to fine tune the focus.
5. Turn the zoom ring locking stem and the focusing stem clockwise to lock the focused position.

5. CAMERA POST INSTALLATION

5.1 Indicator Lights

The camera has amber and green LEDs located on the bottom of the Ethernet connector. The amber light should be on for approximately 30 seconds after power has been applied to the camera. The camera is ready when the amber light turns off. The green LED indicates network connectivity. This light should be on or flashing. Absence of a green light indicates a problem with the Ethernet connection to the camera.

5.2 Configuring The IP Address

The camera ships from the factory with a default IP address of 192.168.1.222. The camera IP address and other network parameters can be changed with the ICM program on the supplied CD-ROM.

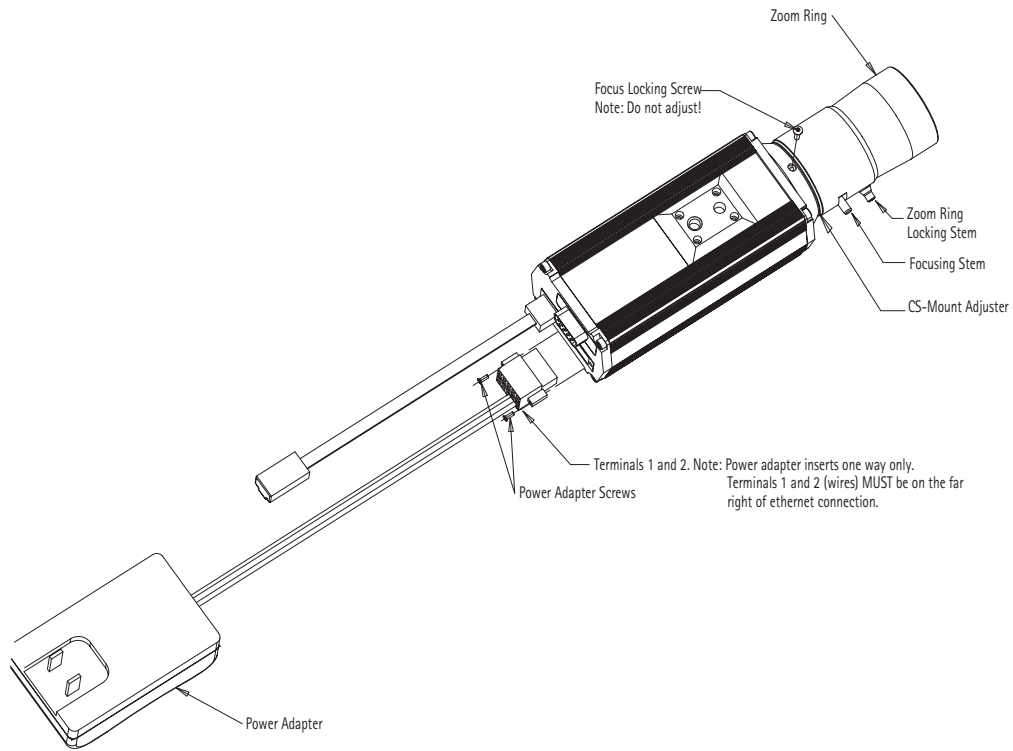

Detail A
Layout of Terminal Block,
Power Connection Guide

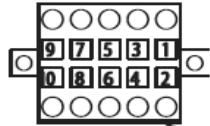

T-slide in the bottom
for orientation

1	Power Connection No Polarity
2	Power Connection No Polarity
3	Alarm Collector
4	Alarm Emitter
5	Trigger Input, Anode
6	Trigger Input, Cathode
7	Not Used
8	Not Used
9	Not Used
10	Not Used

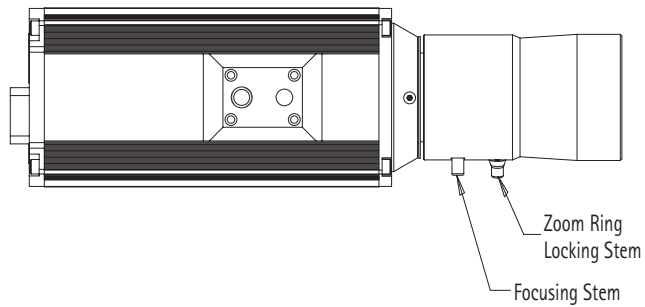
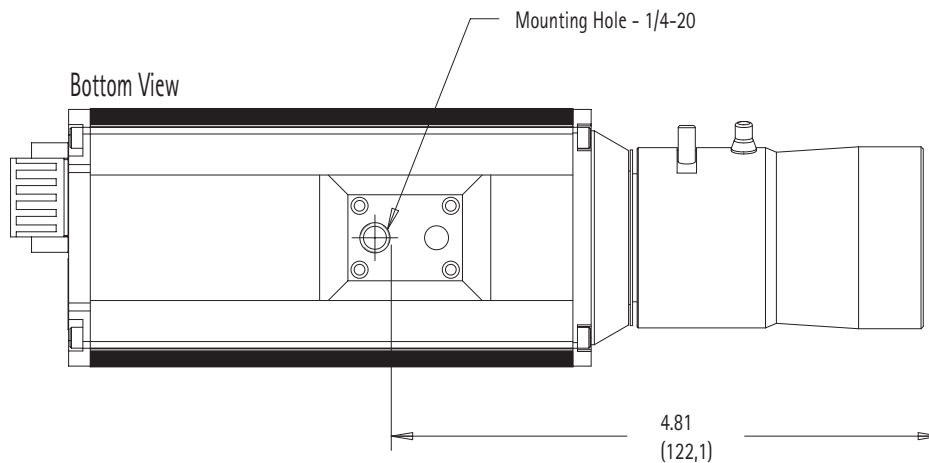
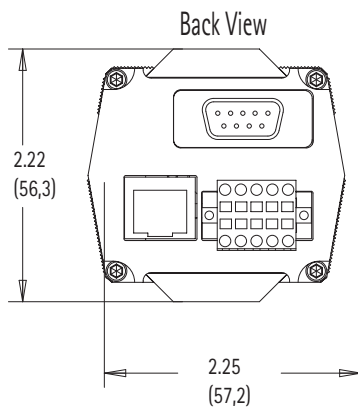
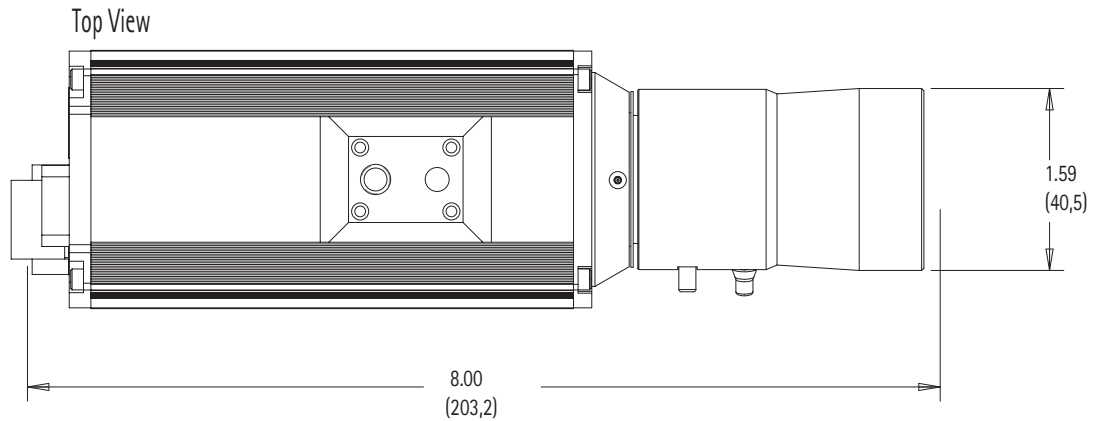

Figure 1 IS-N2000

6. MOUNTING

The camera can be mounted using the 1/4-20 UNC threaded hole (tripod mount) on the camera body or it can be integrated with a camera enclosure.

7. DIMENSIONAL OUTLINE





12120 Sunset Hills Road - Suite 410
Reston, VA 20190
Tel: 703-674-4100 Fax: 703-674-4101

IPIX, CommandView and InSight are trademarks or registered trademarks of IPIX Corporation.
Data subject to change without notice. IB:100 0147 001 IPX 10/05, printed in the U.S.A.